

材 質：1. 熱軋鐵板
2. 鍍鋅鐵板(鋁板)
3. 不銹鋼
表面處理：1. 熱浸鍍鋅
2. 靜電粉體塗裝

MATERIAL: 1. HOT ROLLED STEEL SHEET
2. GALVANIZED STEEL SHEET
3. STAINLESS STEEL SHEET
FINISH: 1. HOT DIP GALVANIZED
2. POWER COATING

垂直分岐連接片
VERTICAL BRANCH PLATE

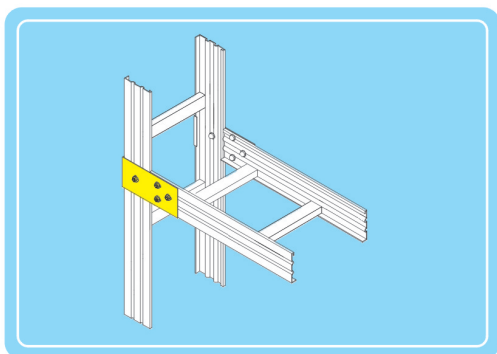

垂直旁接片
SIDE PATH BRANCH PLATE

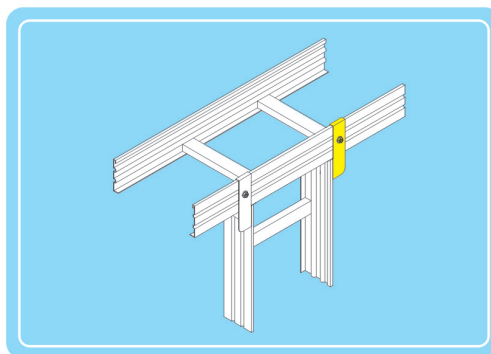

L型壁架
L-TYPE BRACKETS

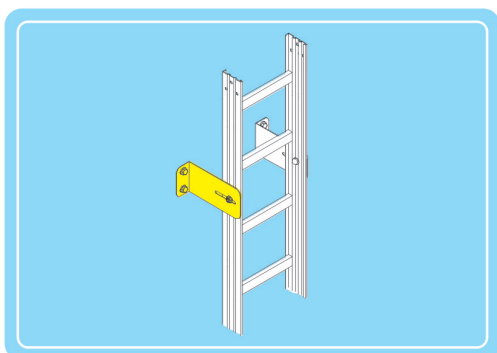

三角型壁架
3-BRACKET

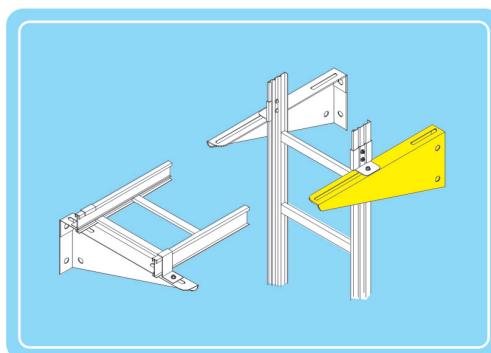

U型壁架
U-BRACKET

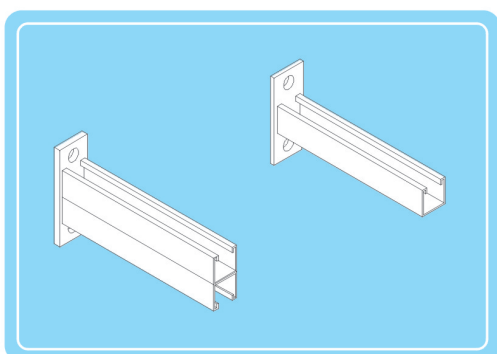

內側固定片
INSIDE HOLD DOWN CLIP

