

材 質：1. 熱軋鐵板
2. 鍍鋅鐵板(鋁板)
3. 不銹鋼
表面處理：1. 熱浸鍍鋅
2. 靜電粉體塗裝

MATERIAL: 1.HOT ROLLED STEEL SHEET
2.GALVANIZED STEEL SHEET
3.STAINLESS STEEL SHEET
FINISH: 1.HOT DIP GALVANIZED
2.POWER COATING

垂直分岐連接片

VERTICAL BRANCH PLATE

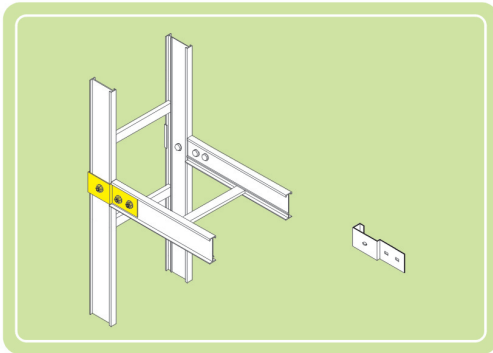

垂直旁接片

SIDEPATH BRANCH PLATE

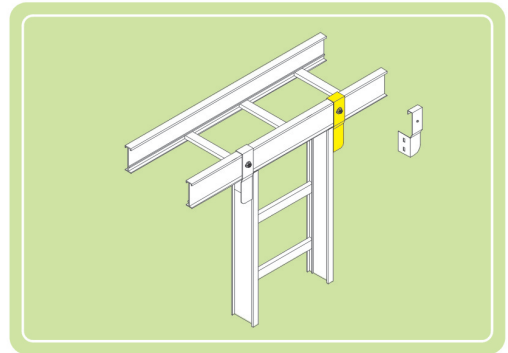

L型壁架

L-TYPE BRACKETS

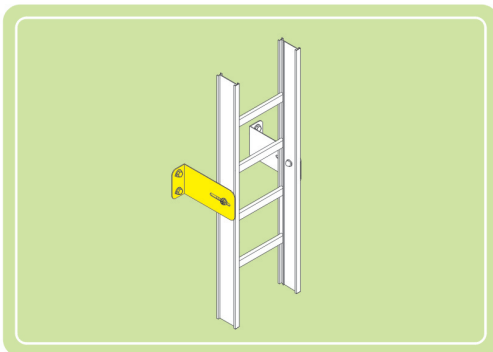

三角型壁架

3-BRACKETES

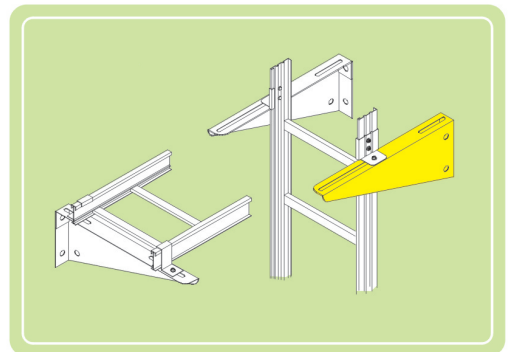

U型壁架

U-BRACKETES

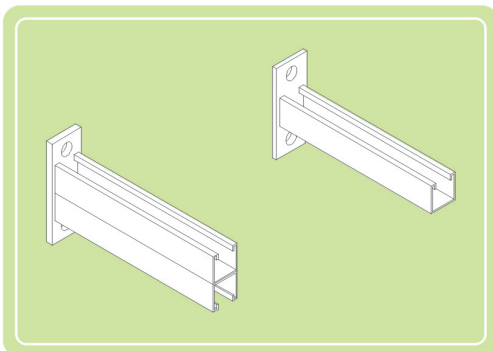

彈簧螺帽

CHANNEL SPRING NUT

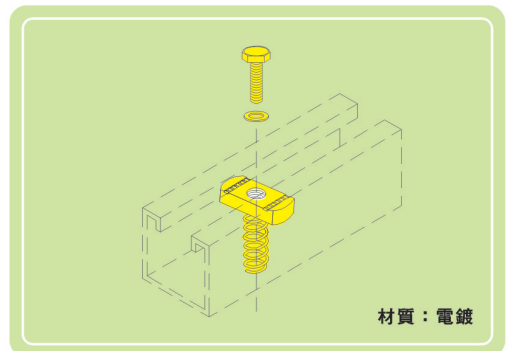

材質：電鍍