

- 材 質：1. 鋁合金 AA 1050
2. 熱軋鐵板
3. 鍍鋅鐵板(鋁板)
4. 不銹鋼
- 表面處理：1. (鋁)陽極處理
2. 電著塗裝
3. (鐵)熱浸鍍鋅
4. 靜電粉體塗裝

- MATERIAL: 1.ALUMINUM ALLOY AA 1050
2.HOT ROLLED STEEL SHEET
3.GALVANIZED STEEL SHEET
4.STAINLESS STEEL
- FINISH: 1.ANODIC OXIDATION
2.ELECTRODEPOSITING COATING AFTER ANODIC OXIDATION
3.HOT DIF GALVANIZED AFTER FABRICATION
4.POWER COATING

直式連接片
STRAIGHT CONNECTOR

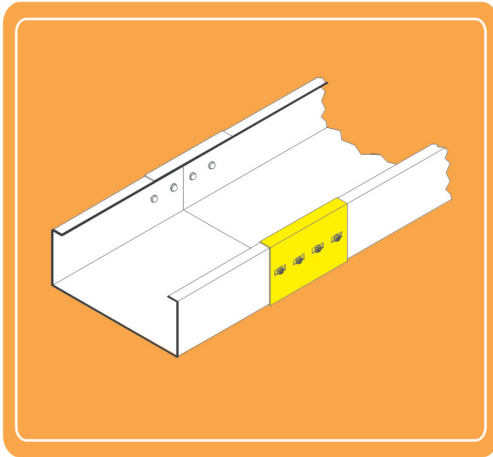

配電盤連接片
PANNEL SPLICE PLATE

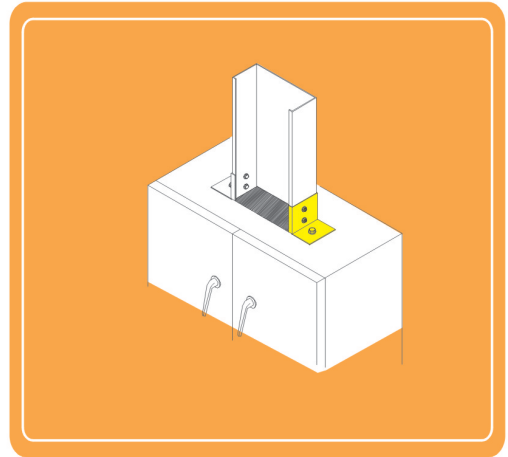

大小頭連接片
REDUCER PLATE

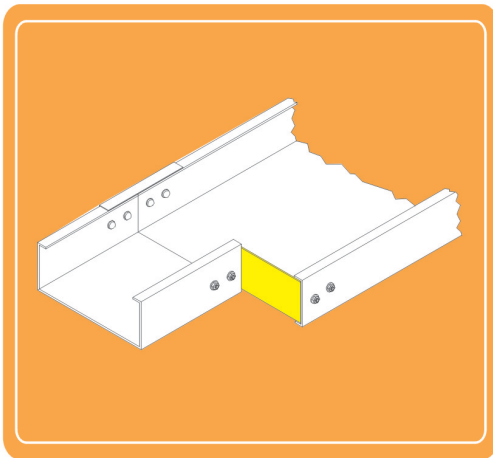

終極封板
BLIND END COVER

